

X12 - X14 - X16

Dimensions, Gearcase			
Model	version	Dy	R
140	R2, R3, R4	185	137
170	R2, R3, R4	185	137
200	R2	242	187
	R3, R4	185	137
220	R2	242	187
	R3, R4	185	137
260	R2	242	187
	R3, R4	185	137

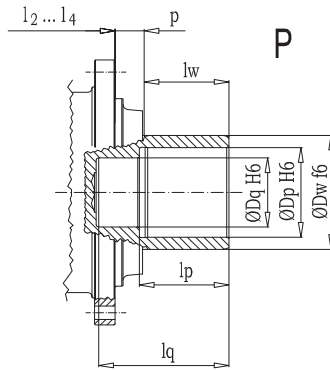

P - shaft version for shrink disc:  
For minimum length of torque reaction arm refer to the relevant data table, value "L<sub>min</sub>"

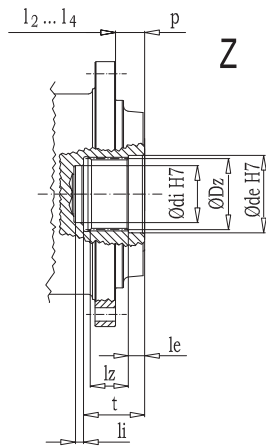
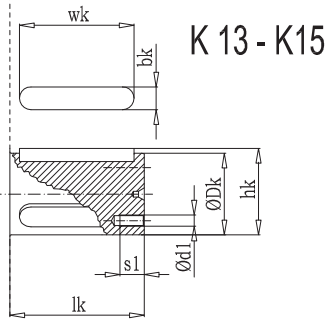
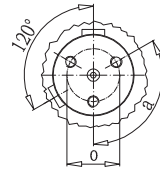

K 13 - K15

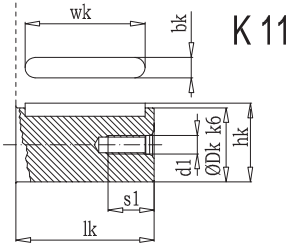
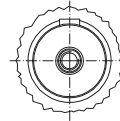

K 11

Data and dimensions are not binding and may be modified without prior notice

Dimensions, standard, solid shafts														Keyed						DIN Splined																		
Model	A	la	B	db	vb	C	lc	D	p	l <sub>2</sub>	l <sub>3</sub>	l <sub>4</sub>	Y <sub>2</sub>	Y <sub>3</sub>	Y <sub>4</sub>	Z <sub>2</sub>	Z <sub>3</sub>	Z <sub>4</sub>	Dk	lk	bk	hk	wk	d1	s1	code	Dx	lx	ls	de	le	di	li	d2	s2	a	o	code
140	325	25	295	16.5	20x18°	230	10	360	36	343	420	420	226	226	276	422	499	499	90	170	25	95	150	M20	50	K 11	80x74	90	50	70	10	85	10	M12	25	3x120°	45	X 12
170	325	25	295	16.5	20x18°	230	10	360	36	343	420	420	226	226	276	422	499	499	90	170	25	95	150	M20	50	K 11	80x74	90	50	70	10	85	10	M12	25	3x120°	45	X 12
200	325	25	295	16.5	20x18°	230	10	360	36	440	425	488	270	226	226	543	504	567	100	165	28	106	140	M14 (3)	30	K 13	100x94	110	66	85	12	105	12	M14	30	3x120°	65	X 14
220	325	25	295	16.5	20x18°	230	10	360	36	460	445	508	270	226	226	563	524	587	100	165	28	106	140	M14 (3)	30	K 13	100x94	110	66	85	12	105	12	M14	30	3x120°	65	X 14
260	325	25	295	16.5	20x18°	230	10	360	36	460	460	523	270	226	226	563	539	602	100	165	28	106	140	M14 (3)	30	K 13	100x94	110	66	85	12	105	12	M14	30	3x120°	65	X 14

Dimensions, reinforced, solid shafts														Keyed						DIN Splined																		
Model	A	la	B	db	vb	C	lc	D	p	l <sub>2</sub>	l <sub>3</sub>	l <sub>4</sub>	Y <sub>2</sub>	Y <sub>3</sub>	Y <sub>4</sub>	Z <sub>2</sub>	Z <sub>3</sub>	Z <sub>4</sub>	Dk	lk	bk	hk	wk	d1	s1	code	Dx	lx	ls	de	le	di	li	d2	s2	a	o	code
140	325	25	295	16.5	20x18°	250	20	360	57	343	420	420	226	226	276	422	499	499	100	165	28	106	140	M14 (3)	30	K 15	100x94	110	66	85	12	105	12	M14	30	3x120°	65	X 16
170	325	25	295	16.5	20x18°	250	20	360	57	343	420	420	226	226	276	422	499	499	100	165	28	106	140	M14 (3)	30	K 15	100x94	110	66	85	12	105	12	M14	30	3x120°	65	X 16
200	325	25	295	16.5	20x18°	250	20	360	57	440	425	488	270	226	226	543	504	567	100	165	28	106	140	M14 (3)	30	K 15	100x94	110	66	85	12	105	12	M14	30	3x120°	65	X 16
220	325	25	295	16.5	20x18°	250	20	360	57	460	445	508	270	226	226	563	524	587	100	165	28	106	140	M14 (3)	30	K 15	100x94	110	66	85	12	105	12	M14	30	3x120°	65	X 16
260	325	25	295	16.5	20x18°	250	20	360	57	460	460	523	270	226	226	563	539	602	100	165	28	106	140	M14 (3)	30	K 15	100x94	110	66	85	12	105	12	M14	30	3x120°	65	X 16

Dimensions, hollow shafts														Hollow for Shrink Disc						Hollow Splined														
Model	A	la	B	db	vb	C	lc	D	p	l <sub>2</sub>	l <sub>3</sub>	l <sub>4</sub>	Y <sub>2</sub>	Y <sub>3</sub>	Y <sub>4</sub>	Z <sub>2</sub>	Z <sub>3</sub>	Z <sub>4</sub>	Dp	lp	Dq	lq	Dw	lw	code	L min. of torque arm	Dz	lz	de	le	di	li	t	code
140	325	25	295	16.5	20x18°	230	10	360	36	343	420	420	226	226	276	422	499	499	110	110	85	160	140	104	P 24	400	80x74	47	85	20	70	10	75	Z 21
170	325	25	295	16.5	20x18°	230	10	360	36	343	420	420	226	226	276	422	499	499	110	110	85	160	140	104	P 24	400	80x74	47	85	20	70	10	75	Z 21
200	325	25	295	16.5	20x18°	230	10	360	36	440	425	488	270	226	226	543	504	567	110	110	85	160	140	104	P 24	500	90x84	48	95	20	70	10	75	Z 23
220	325	25	295	16.5	20x18°	230	10	360	36	460	445	508	270	226	226	563	524	587	110	110	85	160	140	104	P 24	500	90x84	48	95	20	70	10	75	Z 23
260	325	25	295	16.5	20x18°	230	10	360	36	460	460	523	270	226	226	563	539	602	110	110	85	160	140	104	P 24	500	90x84	48	95	20	70	10	75	Z 23

DIMENSIONS IN MM UNLESS OTHERWISE SPECIFIED

Model	140		170		200		220		260	
Torque Rating <sup>①</sup>	14000 Nm		17000 Nm		20000 Nm		22000 Nm		26000 Nm	
R2	NOM. RATIO <sup>②</sup> (ACT. RATING)		NOM. RATIO <sup>②</sup> (ACT. RATING)		NOM. RATIO <sup>②</sup> (ACT. RATING)		NOM. RATIO <sup>②</sup> (ACT. RATING)		NOM. RATIO <sup>②</sup> (ACT. RATING)	
	10 (B)* 25 (B)		10 (B)* 25 (B)		12 (A)		12 (A) 28 (C)		13 (A)	
	12 (A) 30 (B)		13 (A)		14 (A)		16 (B) 34 (D)		16 (B)	
	16 (B) 34 (C)		16 (B)		18 (A)		18 (A)		21 (A)	
	18 (A) * on request		21 (A) * on request		21 (A)		25 (B)		25 (B)	
n <sub>1</sub> nom./max.	3000 rpm	4000 rpm	3000 rpm	4000 rpm	2250 rpm	3000 rpm	2250 rpm	3000 rpm	2250 rpm	3000 rpm
P th. <sup>③</sup> /max.	24 kW	90 kW	24 kW	95 kW	37 kW	100 kW	42 kW	132 kW	42 kW	150 kW
R3	NOM. RATIO <sup>②</sup> (ACT. RATING)		NOM. RATIO <sup>②</sup> (ACT. RATING)		NOM. RATIO <sup>②</sup> (ACT. RATING)		NOM. RATIO <sup>②</sup> (ACT. RATING)		NOM. RATIO <sup>②</sup> (ACT. RATING)	
	38 (B)* 125 (A)		38 (B)* 170 (B)		38 (A) 95 (A)		38 (A) 150 (B)		50 (A)	
	45 (A) 140 (B)		50 (A)		45 (A) 105 (A)		45 (A) 170 (B)		67 (A)	
	53 (B)* 150 (B)		67 (A)		50 (A) 125 (A)		60 (A) 200 (C)		80 (A)	
	60 (A) 170 (B)		80 (A)		60 (A) 150 (A)		71 (A) 240 (D)		95 (A)	
n <sub>1</sub> nom./max.	3000 rpm	4000 rpm	3000 rpm	4000 rpm	3000 rpm	4000 rpm	3000 rpm	4000 rpm	3000 rpm	4000 rpm
P th. <sup>③</sup> /max.	15 kW	30 kW	15 kW	32 kW	15 kW	35 kW	19 kW	60 kW	19 kW	65 kW
R4	NOM. RATIO <sup>②</sup> (ACT. RATING)		NOM. RATIO <sup>②</sup> (ACT. RATING)		NOM. RATIO <sup>②</sup> (ACT. RATING)		NOM. RATIO <sup>②</sup> (ACT. RATING)		NOM. RATIO <sup>②</sup> (ACT. RATING)	
	140 (A) 710 (A)		170 (A) 850 (A)		160 (A) 530 (A)		140 (A) 560 (A)		170 (A) 750 (A)	
	160 (A) 750 (A)		190 (A) 900 (A)		190 (A) 560 (A)		160 (A) 630 (A)		190 (A) 850 (A)	
	200 (A) 850 (A)		220 (A) 1000 (A)		220 (A) 630 (A)		200 (A) 710 (A)		220 (A) 900 (A)	
	220 (A) 900 (B)		250 (A) 1200 (B)		250 (A) 670 (A)		220 (A) 800 (A)		260 (A) 1000 (A)	
	250 (A) 1000 (B)		300 (A)		300 (A) 750 (A)		240 (A) 900 (A)		300 (A) 1200 (B)	
	300 (A) 1050 (B)		340 (A)		340 (A) 800 (A)		260 (A) 1050 (B)		340 (A)	
	340 (A) 1250 (B)		400 (A)		360 (A) 850 (A)		300 (A) 1200 (B)		400 (A)	
	400 (A) 1400 (B)		450 (A)		400 (A) 900 (A)		340 (A) 1400 (C)		450 (A)	
	450 (A) 1600 (C)		480 (A)		420 (A) 1000 (A)		380 (A) 1600 (D)		500 (A)	
n <sub>1</sub> nom./max.	3000 rpm	4000 rpm	3000 rpm	4000 rpm	3000 rpm	4000 rpm	3000 rpm	4000 rpm	3000 rpm	4000 rpm
P th. <sup>③</sup> /max.	11.5 kW	22 kW	11.5 kW	23 kW	11.5 kW	24 kW	13 kW	25 kW	13 kW	26.5 kW
Actual Torque [Nm] <sup>④</sup>	(A) 18000 (B) 15000 (C) 13000		(A) 20500 (B) 18000		(A) 24000		(A) 29000 (B) 23000 (C) 21000 (D) 19000		(A) 32000 (B) 29000	
Peak Torque <sup>⑤</sup>	22000 Nm		26000 Nm		30000 Nm		33000 Nm		35000 Nm	

Data and dimensions are not binding and may be modified without prior notice

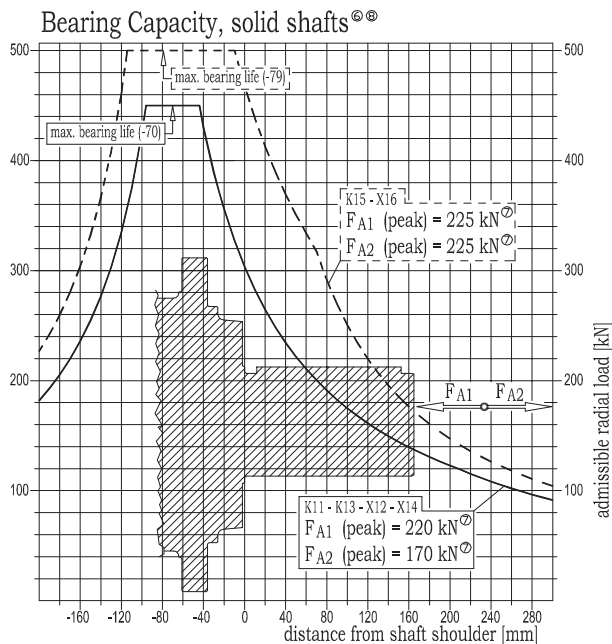

- ① Harmonized nominal value referring to Preferred Numbers R'40. Actual transmissible torque may vary depending on ratio, speed, application.
- ② Harmonized nominal value referring to Preferred Numbers R'40. For actual ratios see Annex C.
- ③ Thermal power limit. For actual figures based on speed, temperature and duty see Section B4, Specifications, Paragraph 8.
- ④ Mean value at rated conditions. For actual figures based on speed, service life and application/duty see Section B4, Specifications, Paragraph 6.
- ⑤ Restrictions may apply for hollow shaft for shrink disc, see Section G, Output Accessories. Customer to verify the mating shaft is capable of loads actually transmitted.
- ⑥ Mean values at rated conditions. For actual admissible loads based on speed, service life and application/duty see Section B4, Specifications, Paragraph 9.
- ⑦ Max. peak values, which must never be exceeded. Combined thrust and radial shaft loads might reduce bearing life. Please contact Plan-Star Engineering for accurate life calculation of your specific application.
- ⑧ Combination of high torque and heavy radial shaft load might require verification of the output shaft. If the following condition is not fulfilled, contact Plan-Star Engineering for accurate verification of your specific application:

$$\frac{\text{Radial Load (applied)}}{\text{Radial Load (admissible)}} \times \frac{\text{Torque (applied)}}{\text{Torque (nominal)}} < 0.5$$