

750, 900, 1100, 1300

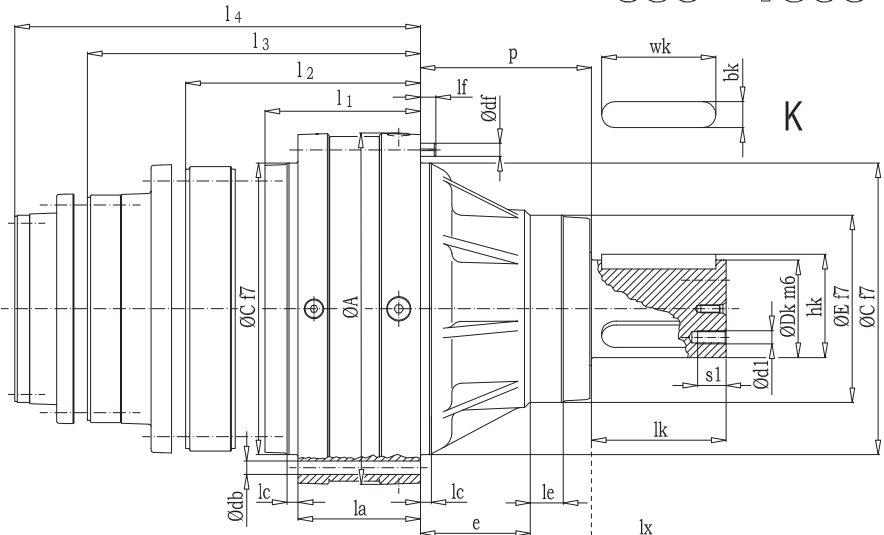

630 only

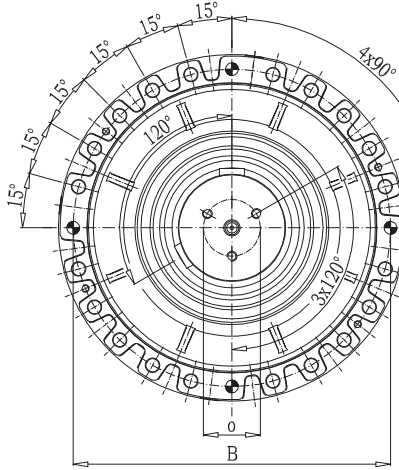
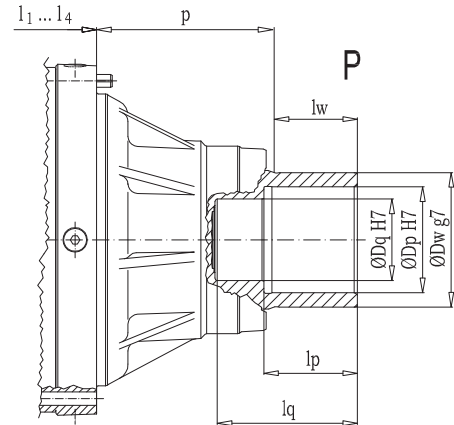
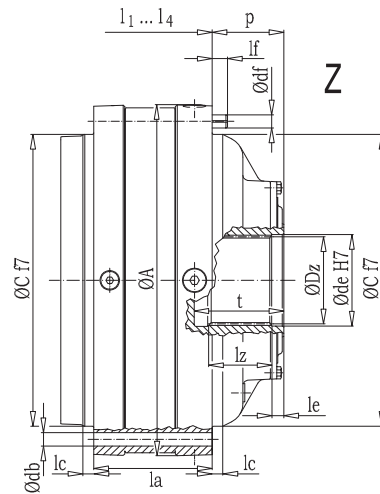
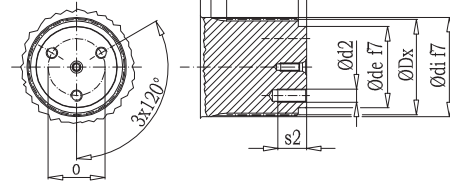

P - shaft version for shrink disc:
For minimum length of torque reaction arm refer to the relevant data table, value "L_{min}"

Data and dimensions are not binding and may be modified without prior notice

Dimensions, solid shafts																	Keyed							DIN Spined												
Model	A	la	B	db	C	lc	E	le	e	df	lf	p	l ₁	l ₂	l ₃	l ₄	Dk	lk	bk	hk	wk	d1	s1	o	code	Dx	lx	ls	di	li	de	le	d2	s2	o	code
630	460	152	415	19	385	13	260	38	152	16	20	227	190.5	242	326	395	130	170	32	137	160	M16	35	70	K 11	130x3	130	88	132	15	110	10	M16	35	70	X 12
750	550	154	503	21	460	13.5	300	30	224	20	25	279	216	320.5	362	431	150	200	36	158	180	M16	35	70	K 11	150x5	150	107	151	15	125	12	M16	35	70	X 12
900	550	154	503	21	460	13.5	300	30	224	20	25	279	216	320.5	362	431	150	200	36	158	180	M16	35	70	K 11	150x5	150	107	151	15	125	12	M16	35	70	X 12
1100	550	184	503	21	460	13.5	300	30	224	20	25	279	246	386.5	418	488	170	200	40	179	180	M16	35	90	K 13	170x5	170	120	171	15	145	12	M16	35	90	X 14
1300	550	184	503	21	460	13.5	300	30	224	20	25	279	246	386.5	418	488	170	200	40	179	180	M16	35	90	K 13	170x5	170	120	171	15	145	12	M16	35	90	X 14

Dimensions, hollow shafts		Hollow for Shrink Disc														Hollow Spined																				
Model	A	B	db	C	lc	df	lf	la	E	le	e	p	l ₁	l ₂	l ₃	l ₄	Dp	lp	Dq	lq	Dw	lw	code	L _{min}	la	p	l ₁	l ₂	l ₃	l ₄	Dz	lz	de	le	t	code
630	460	415	19	385	13	16	20	152	260	38	152	237	190.5	242	326	395	140	145	130	202	185	125	P 22	900	152	81	190.5	242	326	395	130x3	70	132	30	110	Z 21
750	550	503	21	460	13.5	20	25	154	300	30	224	287	216	320.5	362	431	160	160	130	227	200	140	P 22	1100	154	98	216	320.5	362	431	150x5	90	152	20	120	Z 21
900	550	503	21	460	13.5	20	25	154	300	30	224	287	216	320.5	362	431	160	160	130	227	200	140	P 22	1100	154	98	216	320.5	362	431	150x5	90	152	20	120	Z 21
1100	550	503	21	460	13.5	20	25	184	300	30	224	287	246	386.5	418	488	170	170	130	247	220	150	P 24	1100	184	98	246	386.5	418	488	160x5	93	162	20	120	Z 23
1300	550	503	21	460	13.5	20	25	184	300	30	224	287	246	386.5	418	488	170	170	130	247	220	150	P 24	1100	184	98	246	386.5	418	488	160x5	93	162	20	120	Z 23

DIMENSIONS IN MM UNLESS OTHERWISE SPECIFIED

Model	630		750		900		1100		1300	
Torque Rating [Ⓞ]	63000 Nm		75000 Nm		90000 Nm		110000 Nm		130000 Nm	
L1	RATIO (ACT. RATING) 4.5 (A)		RATIO (ACT. RATING) 3.4 (B) 5.3 (B) 4.1 (A)		RATIO (ACT. RATING) 3.4 (B) 5.3 (B) 4.1 (A)		RATIO (ACT. RATING) 3.4 (B) 5.3 (B) 4.1 (A)		RATIO (ACT. RATING) 3.4 (B) 5.3 (B) 4.1 (A)	
n ₁ nom./max.	1200 rpm	1700 rpm	900 rpm	1200 rpm	850 rpm	1200 rpm	800 rpm	1000 rpm	750 rpm	1000 rpm
P th. [Ⓞ] / P mech.	50 kW	370 kW	64 kW	390 kW	70 kW	440 kW	80 kW	515 kW	88 kW	620 kW
L2	NOM. RATIO [Ⓞ] (ACT. RATING) 17 (A) 22 (A) 26 (A) 21 (A) 32 (A)		NOM. RATIO [Ⓞ] (ACT. RATING) 13 (B) 28 (A) 15 (A) 32 (B) 17 (B) 36 (B) 21 (A) 25 (A)		NOM. RATIO [Ⓞ] (ACT. RATING) 13 (B) 28 (A) 15 (A) 32 (B) 17 (B) 36 (B) 21 (A) 25 (A)		NOM. RATIO [Ⓞ] (ACT. RATING) 13 (B) 28 (A) 15 (A) 30 (B) 17 (B) 36 (B) 21 (A) 24 (A)		NOM. RATIO [Ⓞ] (ACT. RATING) 13 (B) 28 (A) 15 (A) 30 (B) 17 (B) 36 (B) 21 (A) 24 (A)	
n ₁ nom./max.	1800 rpm	2500 rpm	1800 rpm	2500 rpm	1800 rpm	2500 rpm	1500 rpm	2000 rpm	1500 rpm	2000 rpm
P th. [Ⓞ] / P mech.	33 kW	230 kW	44 kW	280 kW	48 kW	290 kW	55 kW	330 kW	60 kW	360 kW
L3	NOM. RATIO [Ⓞ] (ACT. RATING) 56 (A) 140 (A) 63 (A) 160 (A) 75 (A) 180 (A) 85 (A) 190 (A) 100 (A) 220 (A) 120 (A) 130 (A)		NOM. RATIO [Ⓞ] (ACT. RATING) 48 (B) 130 (A) 56 (A) 140 (A) 63 (B) 160 (A) 80 (A) 170 (A) 95 (A) 200 (A) 105 (A) 220 (B) 120 (A) 250 (B)		NOM. RATIO [Ⓞ] (ACT. RATING) 48 (B) 130 (A) 56 (A) 140 (A) 63 (B) 160 (A) 80 (A) 170 (A) 95 (A) 200 (A) 105 (A) 220 (B) 120 (A) 250 (B)		NOM. RATIO [Ⓞ] (ACT. RATING) 42 (B)* 120 (A) 48 (B) 140 (A) 56 (A) 170 (A) 67 (B) 200 (A) 80 (A) 220 (B) 90 (A) 250 (B) 105 (A) * on request		NOM. RATIO [Ⓞ] (ACT. RATING) 42 (B)* 120 (A) 48 (B) 140 (A) 56 (A) 170 (A) 67 (B) 200 (A) 80 (A) 220 (B) 90 (A) 250 (B) 105 (A) * on request	
n ₁ nom./max.	2800 rpm	3800 rpm	2000 rpm	3000 rpm	2000 rpm	3000 rpm	2000 rpm	3000 rpm	2000 rpm	3000 rpm
P th. [Ⓞ] / P mech.	20 kW	110 kW	28 kW	150 kW	32 kW	160 kW	35 kW	200 kW	39 kW	220 kW
L4	NOM. RATIO [Ⓞ] (ACT. RATING) 240 (A) 710 (A) 280 (A) 800 (A) 320 (A) 900 (A) 360 (A) 1000 (A) 420 (A) 1100 (A) 480 (A) 1250 (A) 530 (A) 1500 (A) 600 (A)		NOM. RATIO [Ⓞ] (ACT. RATING) 220 (A) 600 (A) 1200 (A) 260 (A) 670 (A) 1400 (A) 300 (A) 710 (A) 1500 (B) 340 (A) 800 (A) 1700 (B) 400 (A) 850 (A) 450 (A) 900 (A) 480 (A) 1000 (A) 530 (A) 1100 (A)		NOM. RATIO [Ⓞ] (ACT. RATING) 220 (A) 600 (A) 1200 (A) 260 (A) 670 (A) 1400 (A) 300 (A) 710 (A) 1500 (B) 340 (A) 800 (A) 1700 (B) 400 (A) 850 (A) 450 (A) 900 (A) 480 (A) 1000 (A) 530 (A) 1100 (A)		NOM. RATIO [Ⓞ] (ACT. RATING) 220 (A) 600 (A) 1200 (A) 260 (A) 670 (A) 1400 (A) 300 (A) 710 (A) 1500 (B) 340 (A) 800 (A) 1700 (B) 400 (A) 850 (A) 450 (A) 900 (A) 480 (A) 1000 (A) 530 (A) 1100 (A)		NOM. RATIO [Ⓞ] (ACT. RATING) 250 (A) 670 (A) 1300 (B) 300 (A) 710 (A) 1500 (B) 340 (A) 800 (A) 400 (A) 850 (A) 450 (A) 900 (A) 480 (A) 1000 (A) 530 (A) 1050 (A) 600 (A) 1200 (A)	
n ₁ nom./max.	2800 rpm	3800 rpm	2800 rpm	3800 rpm	2800 rpm	3800 rpm	2800 rpm	3800 rpm	2800 rpm	3800 rpm
P th. [Ⓞ] / P mech.	16 kW	37 kW	22 kW	63 kW	24 kW	70 kW	27 kW	90 kW	30 kW	100 kW
Actual Torque [Nm] [Ⓞ]	(A) 73000		(A) 94000 (B) 79000		(A) 110000 (B) 95000		(A) 133000 (B) 112000		(A) 160000 (B) 135000	
Peak Torque [Ⓞ]	100000 Nm		140000 Nm		160000 Nm		190000 Nm		215000 Nm	

Data and dimensions are not binding and may be modified without prior notice

Bearing Capacity, solid shafts[Ⓞ]

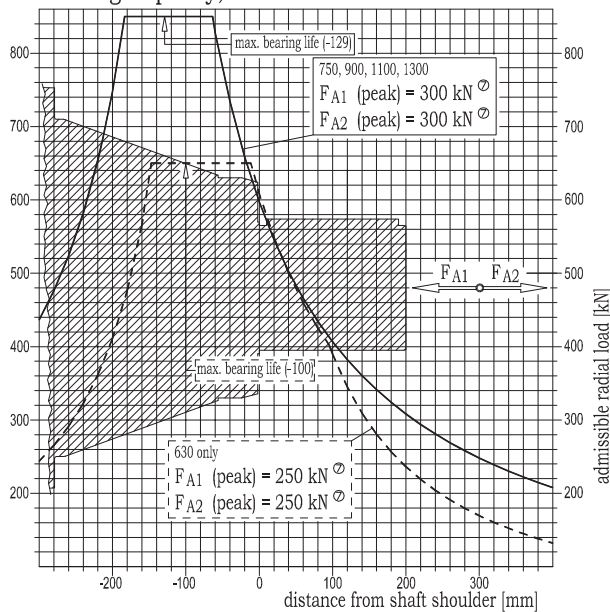

- ① Harmonized nominal value referring to Preferred Numbers R'40. Actual transmissible torque may vary depending on ratio, speed, application.
- ② Harmonized nominal value referring to Preferred Numbers R'40. For actual ratios see Annex C.
- ③ Thermal power limit. For actual figures based on speed, temperature and duty see Section B4, Specifications, Paragraph 8.
- ④ Mean value at rated conditions. For actual figures based on speed, service life and application/duty see Section B4, Specifications, Paragraph 6.
- ⑤ Restrictions may apply for hollow shaft for shrink disc, see Section G, Output Accessories. Customer to verify the mating shaft is capable of loads actually transmitted.
- ⑥ Mean values at rated conditions. For actual admissible loads based on speed, service life and application/duty see Section B4, Specifications, Paragraph 9.
- ⑦ Max. peak values, which must never be exceeded. Combined thrust and radial shaft loads might reduce bearing life. Please contact Plan-Star Engineering for accurate life calculation of your specific application.
- ⑧ Combination of high torque and heavy radial shaft load might require verification of the output shaft. If the following condition is not fulfilled, contact Plan-Star Engineering for accurate verification of your specific application:

$$\frac{\text{Radial Load (applied)}}{\text{Radial Load (admissible)}} \times \frac{\text{Torque (applied)}}{\text{Torque (nominal)}} < 0.5$$